

## ERRATA FOR PRACTICALLY PERFECT PATCHWORK

**Page 12:** There are three columns of quilt diagrams. The quilt layout at the **bottom left corner** (first column) measurements should be **71" x 71"**, not 65" x 65". The quilt at the **top of the second column** (middle of the page) **should be 90" x 60"**, not 91" x 91".

**Page 21:** The following is the **correct illustration** showing the craft knife being used with a **metal cork-backed ruler** to cut the template cardboard. After replacing the illustration with the one below, you can change **"NOTE"** to read: **You can also use a metal utility knife as long as the retractable blade has limited back and forth wiggle in the slot.**

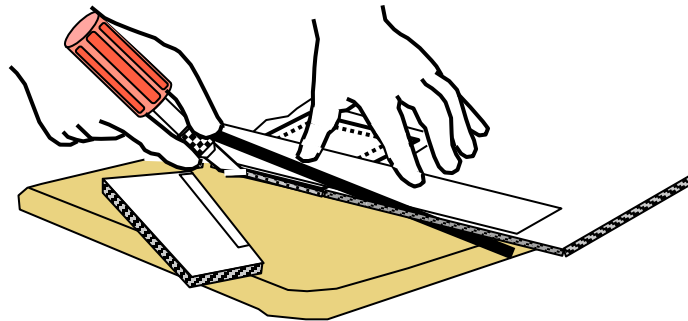

**Page 43:** The illustration for "Step 1" should look like this. Note lower right-hand corner has been cut off.

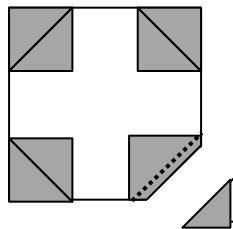

Step 1

**Page 44:** Diagram for "Loop the Loop" is incorrect. It should look like this. Note the change at the lower left-hand corner.

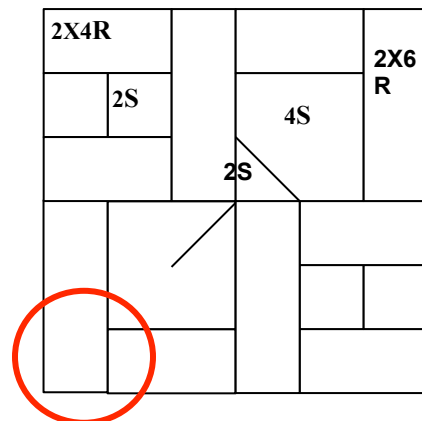

**Page 44:** The box containing the templates to be used to make “**Four Hearts**” (the pattern at the bottom of the page) should read:

Templates:  $1\frac{1}{2}S = \text{Cut } 16$   
 $1\frac{1}{2}X3R = \text{Cut } 8$   
 $1\frac{1}{2}X6R = \text{Cut } 4$   
 $3X6R = \text{Cut } 4$

**Page 50:** The black, white and yellow block in the top of the fourth column should be named, **54- 40 or Fight**

**Page 68:** The quilt block at the lower left corner of the page is “**Windblown Square**” and should look like this:

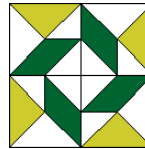

Compare the illustration on page 68 with the one on page 67 (second block in the first column). **The block on page 67 is correct.**

**Page 76:** The box containing the templates to be used to make “**Windblown Square**” (the pattern at the bottom of the page) should read:

Templates:  
 $3RT = \text{Cut } 8$   
 $1\frac{1}{4} 6S = \text{Cut } 8$   
 $1PAL 1 = \text{Cut } 4$

**Page 88:** **TRAP 2** needs a grain line arrow. It should look like this:

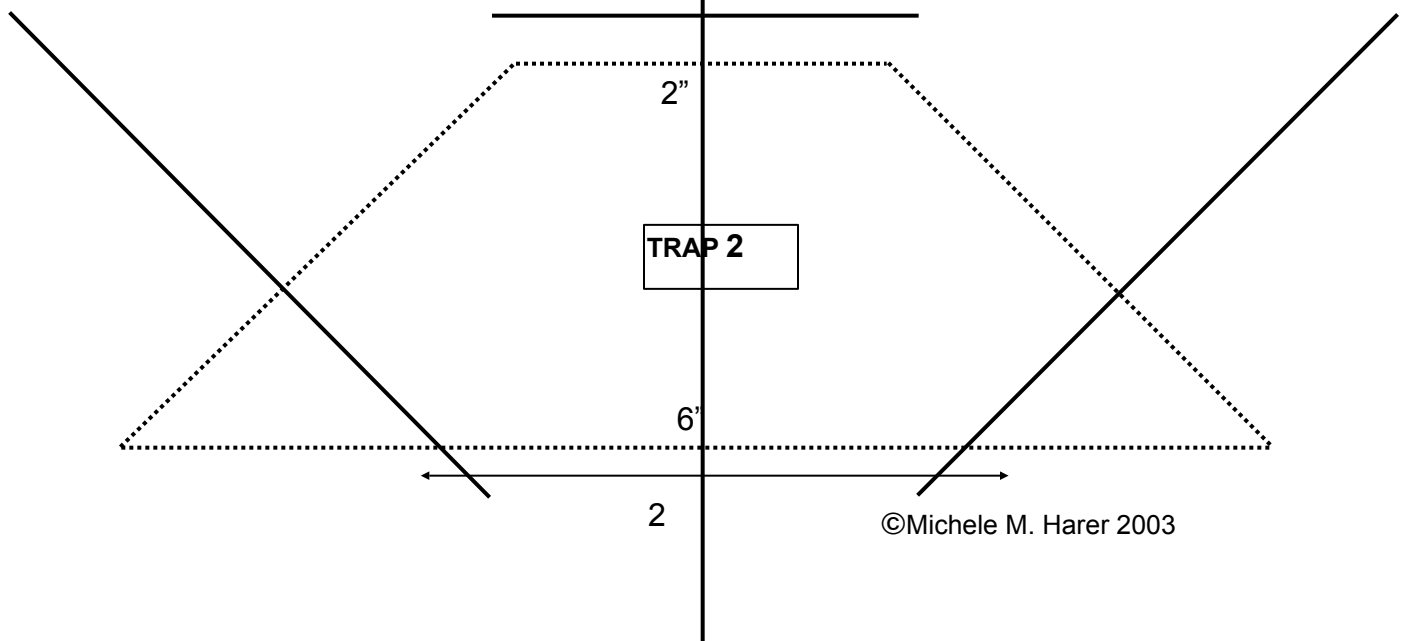

Page 101: “Baby  
template box

Templates:  
3S = Cut 4  
IN2X2QC to cut the “bite” out of 3S  
2X2QC = Cut 4  
3X3A Easy Arc = Cut 12  
3X3QC = Cut 12

“Buds”  
should read:

**Page 109:** In the “Materials” box at the bottom of the page, the correct size nickel-plated safety pins (11<sup>th</sup> starred item) should be **Size #2** not size 1.

**Page 115:** The third paragraph under the heading, “How Does Your Quilt Top Look So Far?” should read:

**When you find the arrangement you like, sew a sash to the top of each block in the first row. We need to assemble the quilt in uneven quarter sections as shown to avoid long seams that will make the sashing appear “wavy.” Attach the side sashes and cornerstones to each other to fit the quarter section configurations. Then sew the block/sashing units to the joined sash/cornerstone units.**

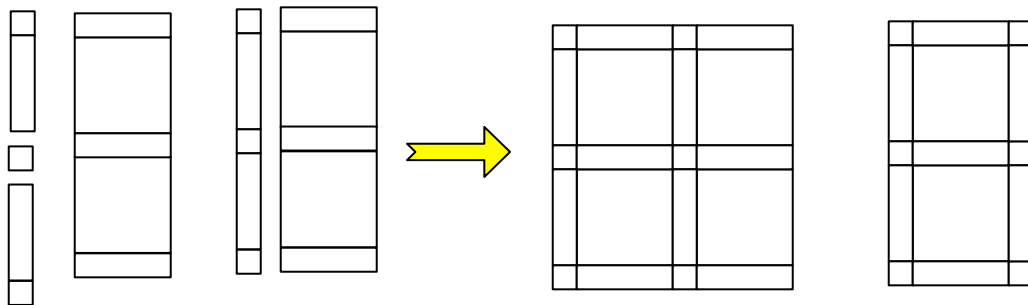

**Sew the perpendicular sashing/cornerstone strips to each other so they match up to the block/sashing strips you just made.**

